

■ GENERAL DESCRIPTION

In portable equipment, supply current increases depending on input sources, such as an AC adapter or a battery, and the operation mode, such as stand-by mode (Low Active) or operation mode (High Active). For reducing the supply current, an applied voltage to the core of the CPU, etc. is often switched. Since there is a limit to a power, which a battery can supply, the operating time of portable equipment can be lengthened by decreasing the applied voltage. For a DC/DC converter like TOREX's XC6365/XC6366 series, which can set up an output voltage externally, the output voltage switch function is generally used.

This Technical Information Paper introduces the usage of the XC6401 series, which consists of low noise dual regulators, and enables switching output voltage.

■ FEATURES

- Using only one output capacitor (CL)
- Switching output voltage by external control
- No Schottky diode for preventing reverse current is needed
- Low noise

■ OPERATIONAL EXPLANATION

When both EN1 and EN2 pins are High Active, the higher voltage is outputted among the output voltage at regulator 1 (VOUT1) and regulator 2 (VOUT2). As for the current limit characteristic, the current limit starts to operate when the output voltage at regulator 2 (VOUT2) is 3.3V@IOUT=300mA and voltage falls to 2.8V, which is the same voltage as the setting output voltage at regulator 1. Also 300mA current of regulator 1 is added. Supply current flows about 50μA, which value is twice larger than the current when either EN1 or EN2 pin is High Active. Please refer to the figure 1 below for load transient response. When either EN1 or EN2 pin is High Active, the output voltage of 3.3V at regulator 1 (VOUT1), and that of 2.8V at regulator 2 (VOUT2) are outputted. For the current limit characteristics of VOUT1 and VOUT2, please refer to the figure 2 below.

■ TYPICAL APPLICATION CIRCUIT

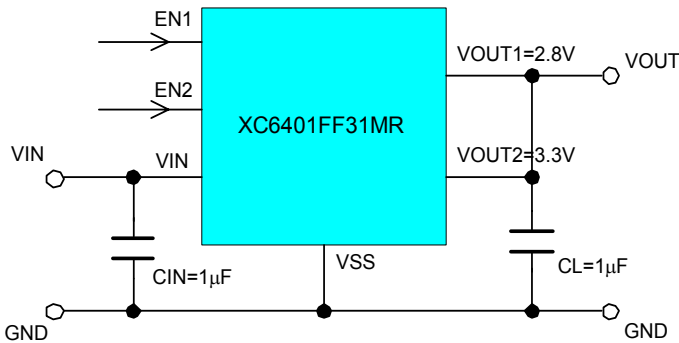

EN1	EN2	VOUT	ISS
High Active	High Active	3.3V ⇄ 2.8V	50μA
High Active	Low Active	2.8V	25μA
Low Active	High Active	3.3V	25μA
Low Active	Low Active	0V	0.01μA

* The value of the output voltage (VOUT) and the supply current (ISS) when giving High Active to the EN1 pin and Low Active to the EN2 pin are typical value.

** The supply current value (ISS) when giving Low Active to the EN1 pin and the EN2 pin is a value in the stand-by mode.

■ TYPICAL PERFORMANCE CHARACTERISTICS

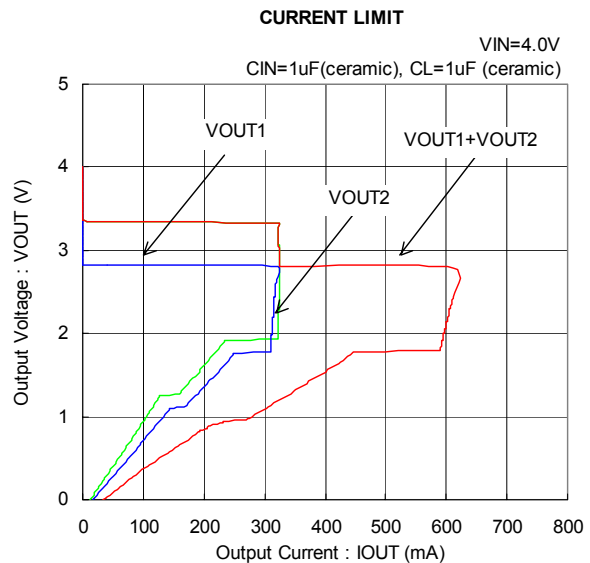
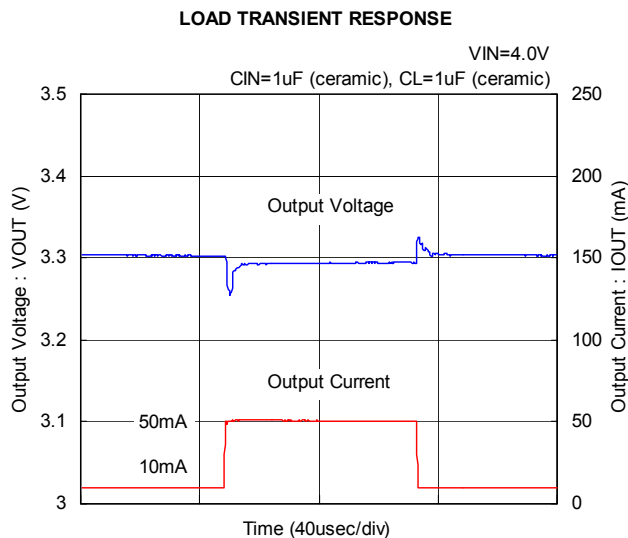

Note: Input and output capacitor:

A compact ceramic capacitor in 1005 or smaller sizes may greatly decrease an electrostatic capacity when measuring the DC bias characteristics. In this case, the IC may oscillate because of the insufficient capacity of the IC. As solution, please add the electrostatic capacity, or use a ceramic capacitor with high voltage.