

Power Management Solutions

IN THIS ISSUE

- **3MHz Synch Step-Down DC/DC Converter**
XC9235/36/37
- **Sync Step-Down DC/DC Converter**
XC9223/24
- **Dual Sync Step-Down DC/DC Converter**
XC9515
- **Low Voltage Input LDO Regulators**
XC6601
- **High Side Switch**
XC8101
- **0.8V Synch Step-Up DC/DC Converter**
XC9128/29
- **28V High Speed CMOS LDO Regulator**
XC6701
- **1 μ A Iq LDO Regulator**
XC6218
- **High Speed, Low Noise LDO Regulator**
XC6221
- **Dual High Speed, Low Noise LDO Regulator**
XC6415
- **PLL Clock Generator IC**
XC25BS7
- **Schottky Barrier Diodes**



Buck Converters

XC9235/36/37 3MHz Synch Step-Down DC/DC Converter

- XC9235 PWM control
- XC9236 PWM/PFM (auto-switching)
- XC9237 PWM/PFM (manual)

The XC9235/36/37 series are synchronous step-down DC/DC converters with 0.42Ω (typ) P-channel driver transistor and a 0.52Ω (typ) N-channel switching transistor built-in. With a high switching frequency of 3MHz, a low profile inductor and two caps connected externally are all that are needed to configure a highly efficient step-down circuit capable of handling up to 600mA. Output voltage is externally set within a range of 0.8V~4.0V in 50mV steps. Operating voltage range is 2.0V~6.0V.

Key Features

- Input Voltage: 2.0V ~ 6.0V
- Output Voltage: 0.8V ~ 4.0V
- Output Current: 600mA
- Switch Frequency: 1.2MHz, 3.0MHz (+/-15%)
- Compatible with Low ESR/Ceramic Capacitors
- Soft-Start Circuit Built-In
- Current Limiter Circuit Built-In (Constant Current & Latching)
- Small SOT23-5 or USP-6C chip scale package (2.0mm x 1.8mm x 0.6mm)

Output Voltage Ripple

By using ceramic output capacitors, the XC9235/36/37 achieves a voltage output ripple that remains very low over the whole range of load currents, including near the PFM/PWM switching point. With similar products, the output ripple tends to increase quite a lot in the vicinity of this point, but with the XC9236 & XC9237, as you can see from the graph data below, Torrex's DC/DC maintains a very low ripple throughout. In wireless

applications (such as GPS, WiFi, Bluetooth etc.) where the purity of the carrier is of paramount importance, it can be required for signals entering the processing chip to be at less than 10mV of ripple, so that no spurious appears along the carrier on the frequency spectrum. In such cases, using the XC9235/36/37 guarantees that this low ripple condition is fulfilled whatever the load current.

Lowest possible ripple across all switching conditions!

KEY

Green Waveform:
VOUT 10mv/div

Red Waveform:
Inductor Current 100mA/div

PFM:
Pulse Frequency Modulation

PWM:
Pulse Width Modulation

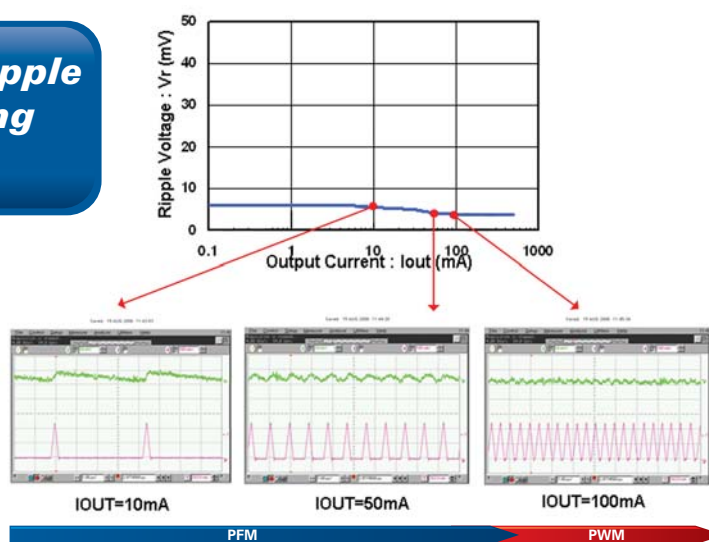

Note: The switchover point from PFM mode to PWM mode will vary depending upon the voltage conditions

Buck Converters

The XC9235 series is PWM control, and the XC9236 series is PWM/PFM mode, which automatically switches from PWM to PFM during light loads meaning that high efficiencies (see graph

below) can be achieved over a wide range of load conditions. The XC9237 allows the user to select either PWM only or PWM/PFM auto switching via the CE/Mode pin.

Typical Performance Characteristics

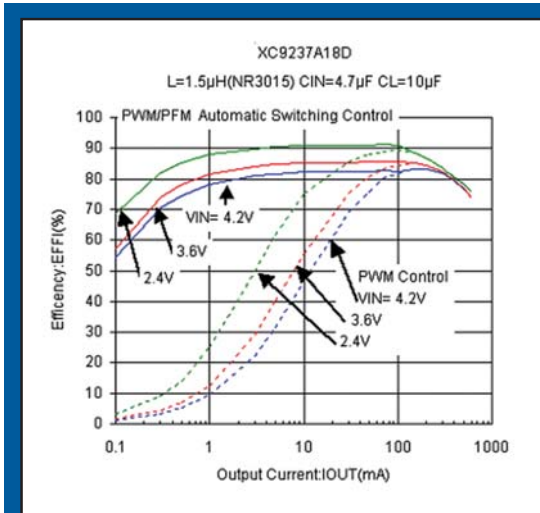

Efficiency

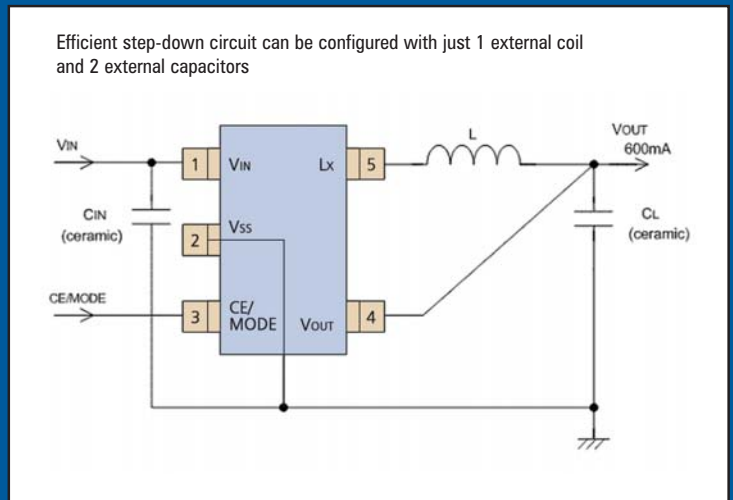

Typical Application Circuit

Soft-Start Time

As highlighted in the graphs below, a new "B" version of the series is also now available which will offer a shorter soft-start

time of 0.2ms, which is 0.8ms faster than the "A" version. The "B" version will also feature a CL discharge function.

VIN=4.2V IOUT=1mA

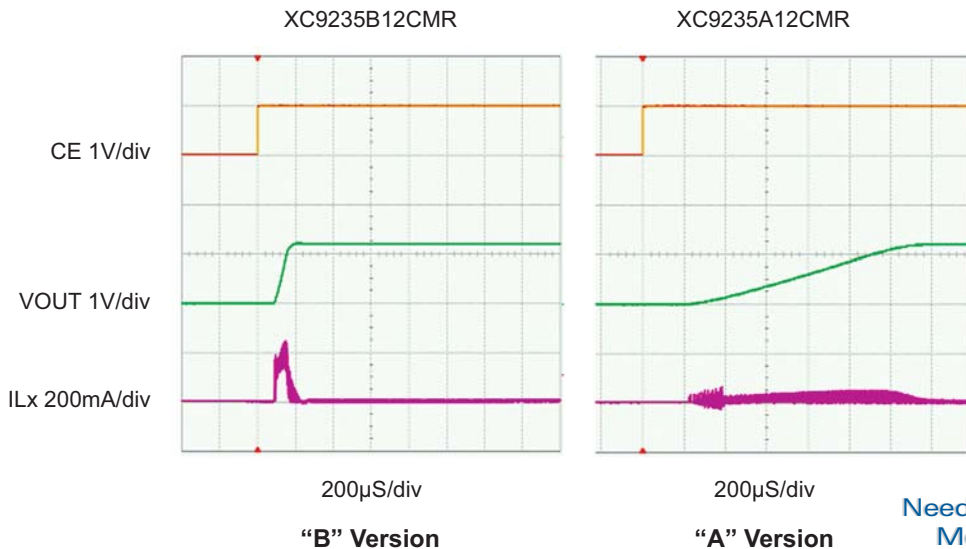

Buck Converters

XC9223/24 1A Sync Step-Down DC/DC Converter

- Input Voltage: 2.2V ~ 6.0V
- Output Voltage: 0.8V ~ Vin
- Max. Output Current: 0.5A @ LIM pin = H
1.5A @ LIM pin = L
- Oscillator Frequency : 1MHz, 2MHz
- Integral Voltage Detector
- Packages : MSOP10, USP10

The XC9223/9224 series are synchronous step-down DC/DC converters with an integral 0.23Ω (TYP.) P-channel and a synchronous 0.25Ω (TYP.) N-channel switching transistor built-in.

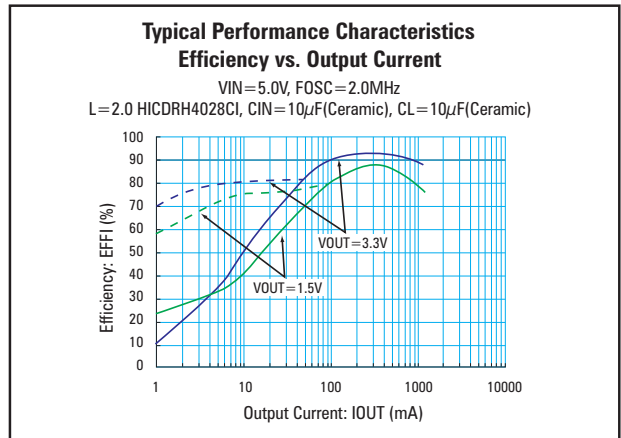
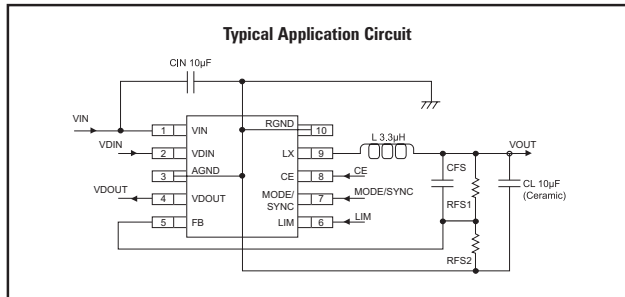

XC9515 Dual Sync Step-Down DC/DC Converter

Under Development

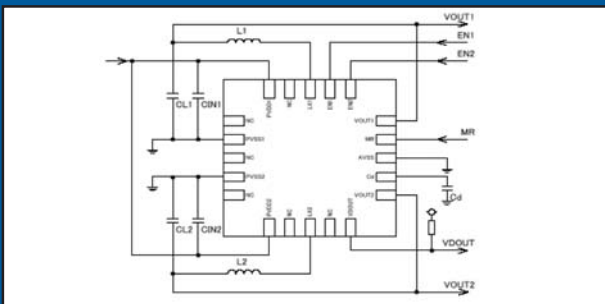

Typical Application Circuit

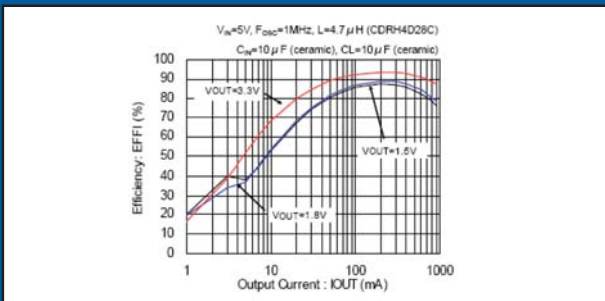

Efficiency

- Input Voltage Range: 5.0V +/-10%
- Output Voltage: DC1 selectable from 1.2V, 1.5V, 1.8V
DC2 fixed at 3.3V
- Switching Frequency: 1MHz
- Output Current: 800mA / channel
- Package: QFN-20 (4mm x 4mm x 0.75mm)

The XC9515 series is a dual-channel synchronous step-down DC/DC converter with built-in voltage detector (delay time set externally via Cd pin) that can monitor voltage levels between 3.5V~4.5V. With a 0.35Ω (TYP.) P-channel driver transistor and a synchronous 0.35Ω (TYP.) N-channel switching transistor built-in, the XC9515 can deliver highly efficient step-down solutions with stable output currents up to 800mA / channel.

Control is PWM and the XC9515 also integrates thermal shutdown, short circuit and integral latch (over-current limit) protection circuits.

Need Companion Solutions?

LDO Voltage Regulators

XC6601 Ultra Low Dropout LDO Regulator

The XC6601 offers a new concept in low voltage power management. By powering the internal N-channel pass transistor via a V_BIAS pin, power to the IC can be taken directly from the battery (up to 6V). This means that the actual VIN supply to the XC6601 can be taken, for example, from the output of a step-down DC/DC such as Torex's 3MHz switching XC9236. Due to the extremely low dropout voltage performance of only 35mV @ 100mA, the XC6601 is an ideal solution for low voltage input regulation, providing low, stable output voltages down to 0.7V from equally low inputs!

Key Features

- Maximum Output Current: 400mA (500mA limit Typ)
- Dropout Voltage: 35mV@ 100mA
- Bias Voltage Range: 2.5V ~ 6.0V
- Operating Voltage Range: 0.9V ~ 3.0V

- Output Voltage: 0.7V ~ 1.8V (50mV increments)
- Output Voltage Accuracy: +/-20mV
- CL High Speed Auto Discharge
- Packages: USP-6C, SOT-25 & SOT89-5

Typical Application Circuit

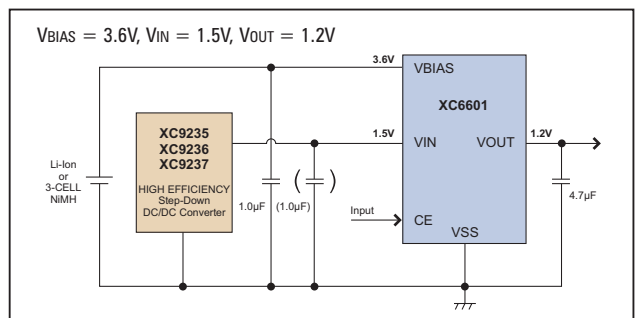

XC8101 High Side Switch

The XC8101 is a low voltage P-Channel MOSFET power switch for high load switching applications. The XC8101 has ON/OFF control and is a perfect solution when you need to provide a series of stable voltage outputs. By connecting, for example, the XC8101's VIN pin to the output pin of a step-down DC/DC converter such as the XC9235, the line switcher can be used to provide a number of accurate & efficient output rails. The XC8101's CE pin

controls the ON/OFF for each switcher to deliver power as and when needed thereby maximizing overall efficiency. No external capacitors are needed so the XC8101 is also a space saving solution where board space is at a premium.

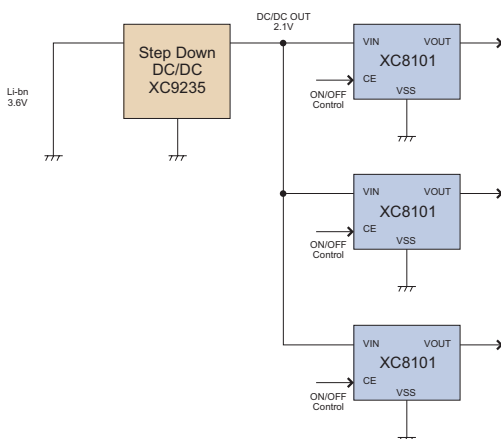

- Input Voltage Range: 1.8V ~ 6.0V
- ON Resistance: 0.75Ω @ VIN=2.9V
1.15Ω @ VIN=1.8V
- Power Consumption: 2µA
- Stand-by Current: 0.1µA
- Output Current: 200mA
- High Speed Discharge Function
- ON/OFF Function
 - High Active Enable
- Protection Circuit:
 - Current Limit 300mA (typ)
 - Short Circuit Protection
 - Short Current 30mA (typ)
- Packages: USP-4, SC-82, SOT-25

Boost Converters

XC9128/29 0.8V Synch Step-Up DC/DC Converter

Coming Soon!

The XC9128/29 series are synchronous step-up DC/DC converters with 0.2Ω (typ) N-channel driver transistor and a synchronous 0.2Ω (typ) P-channel switching transistor built-in. With a high switching frequency of 1.2MHz, a small inductor can be used making the XC9128/29 ideally suited to applications with limited board space. Output voltage is externally set within a range of 1.8V ~5.3V using a reference voltage supply of 0.45V and split resistors.

Unlike the XC9129, the XC9128 series incorporates an AEN (Adaptor Enable) pin which allows the XC9128 to also be used to provide a fast power supply back-up solution when the IC is used together with added power sources such as AC adaptors. The AEN pin monitors the external power source and can quickly sense if that power supply fails, providing immediate back-up.

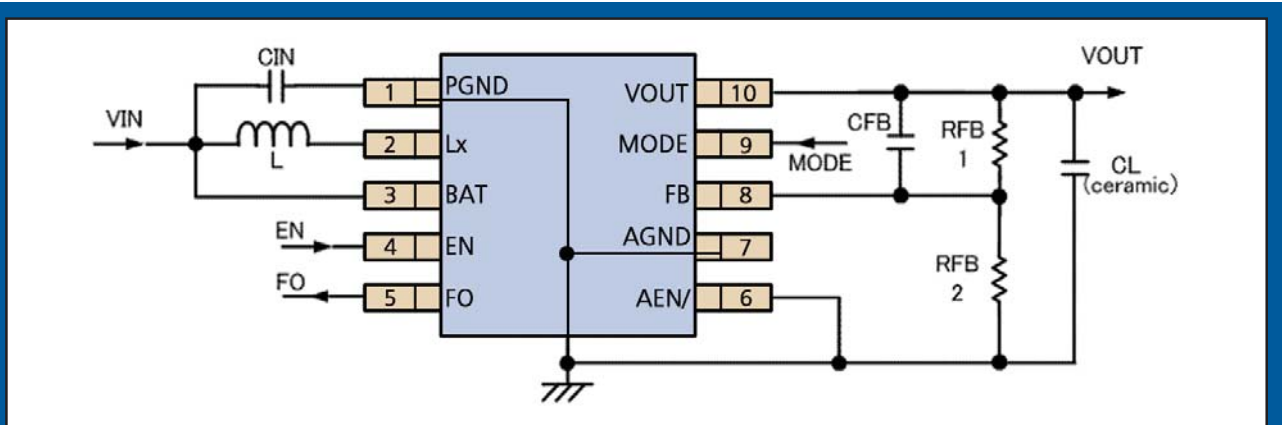

Typical Application Circuit

Key Features

- Output Voltage Range: 1.8V~5.3V (externally set)
- Operating Voltage Range: 0.8V~6.0V
- Output Current: 150mA (0.9V to 3.3V step-up)
500mA (1.8V to 3.3V step-up)
- Oscillation Frequency: 1.2MHz (+/-15%)
- Input Current: 1A
- Maximum Current Limit: 1.2A (min); 2A (max)
- Control: PWM; PWM/PFM
- Protection Circuits: Thermal Shutdown, Over-Current Limit
- Soft-Start Time: 5ms (typ) internally set
- Adaptor Enable Function (AEN pin)
- Packages: USP-10B & MSOP-10 (XC9128); SOP-8 (XC9129)

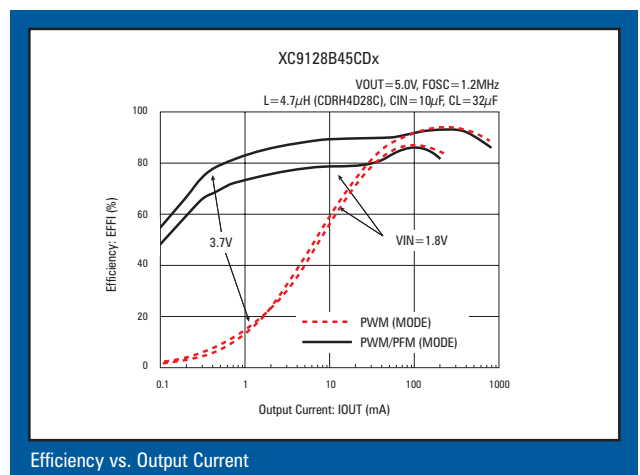

Efficiency vs. Output Current

LDO Regulators

XC6701 28V High Speed CMOS LDO Regulator

The XC6701 is a new high speed (50dB @ 1kHz ripple rejection), 28V linear LDO voltage regulator ideally suited for 24V systems and many industrial applications. Even in full operation, the XC6701 only consumes 20 μ A of current and this can be greatly reduced via the IC's chip enable (CE) pin to less than 0.1 μ A in stand-by. Output voltage is selectable in 100mV steps within the range of 1.8V to 18V. The XC6701 is compatible with ceramic caps for added stability and the series also includes built-in over current protection and thermal shutdown circuits.

Key Features

- Input Voltage: 2.0V~28.0V
- Output Voltage: 1.8V~18.0V (100mV increments)
- Maximum Output Current: 200mA
- Dropout Voltage: 300mV@ Iout=20mA
- High Accuracy: \pm 2%

- Low Power Consumption: 20 μ A
- Stand-by Current: <0.1 μ A
- Ripple Rejection: 50dB @ 1kHz
- Packages: SOT-25, SOT-89, SOT-89-5, USP-6C, SOT-223, TO-252

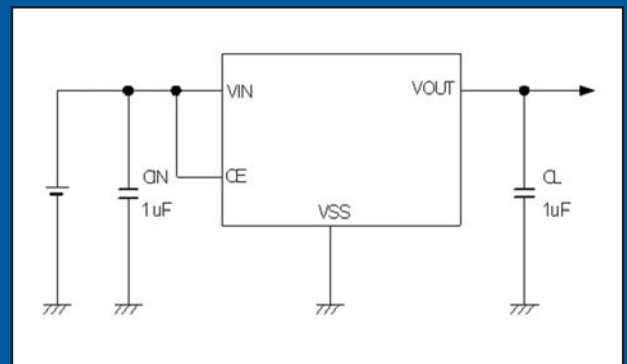

Typical Application Circuit

XC6218 3 Pin LDO Regulator

Very low quiescent current, only 1 μ A in operation, makes the XC6218 ideal for power critical applications. Designed for use with low ESR ceramic capacitors, which give added output stability, the XC6218 is capable of handling currents over 200mA. In addition, the tiny USP-3 package, which measures just 1.2mm x 1.2mm and is only 0.6mm high, means that the XC6218 can also save on valuable PCB space. The current limiter's fold-back circuit also operates as a short circuit protection.

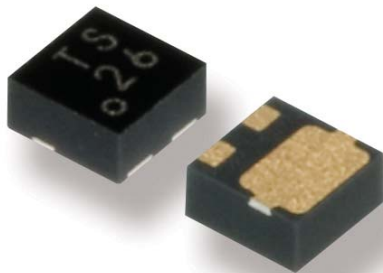

Key Features

- Maximum Output Current: 200mA (300mA limit Typ)
- Dropout Voltage: 200mV@ 100mA
- Operating Voltage Range: 1.5V ~ 6.0V
- Output Voltage: 0.9V ~ 4.0V (100mV increments)
- Low Power Consumption: 1.0 μ A (typ.)
- Low ESR Capacitor - Ceramic capacitor compatible
- Small Packages: USP-3 & SSOT-24

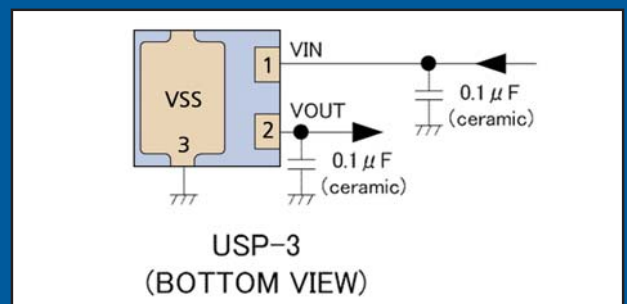

Typical Application Circuit

LDO Regulators

XC6221 LDO Regulator



The new XC6221 high speed, low noise LDO is probably our best LDO to date in terms of overall performance. Excellent load transient response performance (refer to graph) is backed up with a drop-out specification of only 80mV @ 100mA and a PSRR figure of 70dB @ 1kHz! Add to

this the fact that the XC6221 only consumes 25 μ A in operation and has output voltages selectable in the range of 0.8V~4.0V in 50mV steps and you can see why the XC6221 is such a fantastic LDO. Did we mention the fact that the **B & D** versions also include a CL auto-discharge function? Available in USP-4, SSOT-24 & SOT25 packages.

Key Features

- Output Range: 0.8V to 4.0V
- Input Range: 1.6V to 6.0V

- Output Current: 200mA (250mA Limiter)
- Dropout Voltage: 80mV @ 100mA
- Quiescent Current: 25 μ A
- Ripple Rejection: 70dB @ 1kHz
- Options: CL Auto Discharge on XC6221B/D Series
- Package : USP-4D, SOT25, SSOT24

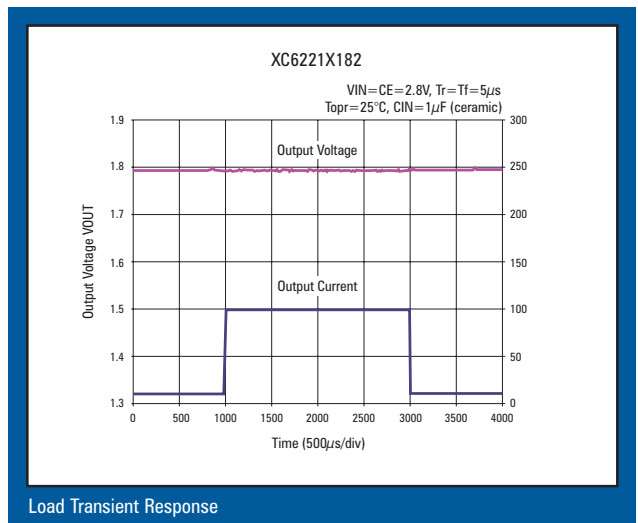

XC6415 Dual LDO Regulator

With output voltages independently selectable in the range of 0.8V~5.0V and minimal cross talk, the new XC6415 is an ideal solution for space sensitive applications.

Key Features

- Output Range: 0.8V to 5.0V
- Input Range: 1.5V to 6.0V
- Output Current: 200mA (300mA Limiter)
- Dropout Voltage: 90mV@100mA

- Quiescent Current: 28 μ A / Channel
- Ripple Rejection: 65dB @ 1kHz
- Options: CL Auto Discharge
- Package: USP-6C, SOT26

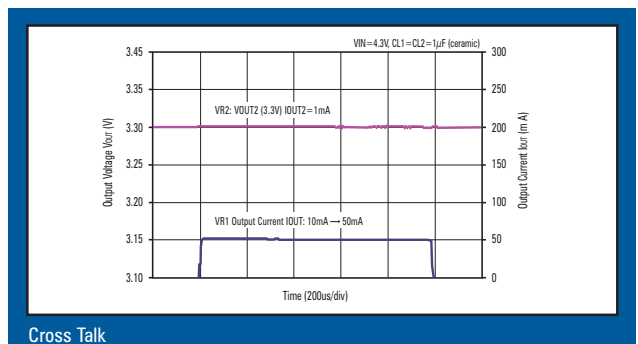

Coming Soon!

XC6416 Dual "GO" Green Operation LDO with innovative auto power save function

PLL Clock Generator ICs

XC25BS7 PLL Clock Generator IC

- Input Frequency: 32kHz ~ 36MHz
- Output Frequency: 1MHz ~ 100MHz ($f_{Q0}=f_{CLKin} \times N/M$)
- Operating Voltage Range: 2.5V ~ 5.5V
- Output Divider (N): 1~256
- Input Divider (M): 1~256
- Low Power Consumption: 10 μ A
- Package: SOT-25 & USP-6C

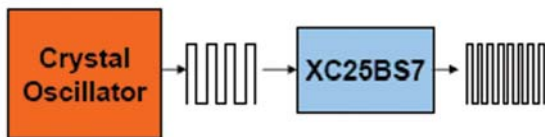

The XC25BS7 is a new clock generator IC with built-in divider & multiplier circuits. A wide range of accurate output frequencies within a range of 1MHz ~ 100MHz can be generated from standard clock signals.

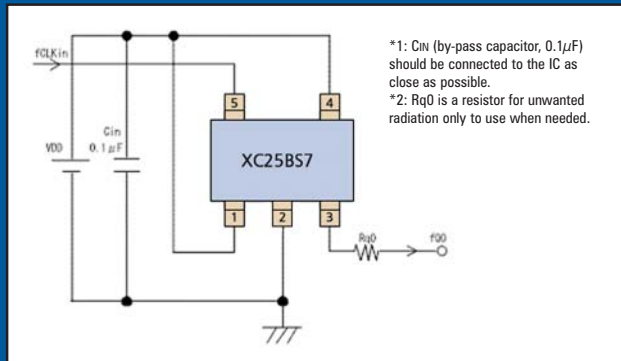
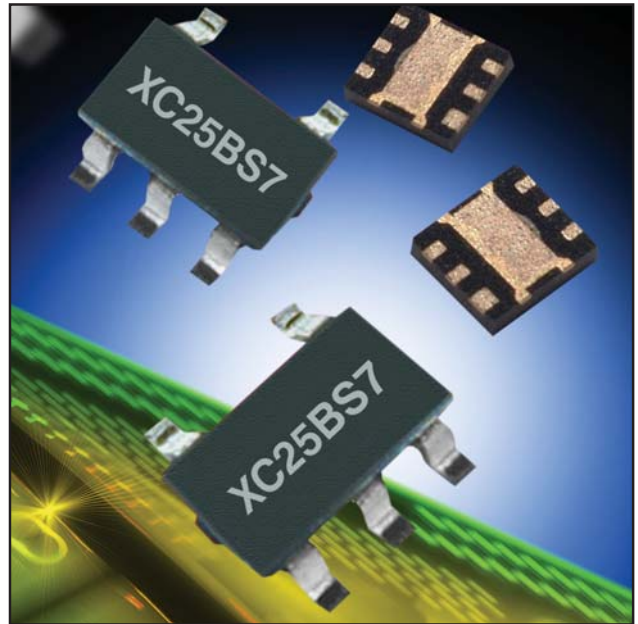

Typical Application Circuit

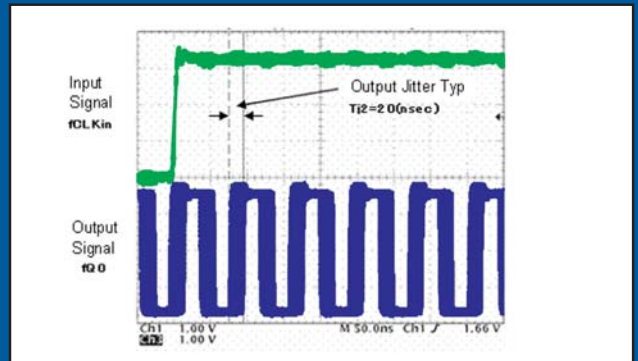

Typical Performance

Example Part Numbers:

Part Number	Input Frequency	Multiplier/Divider Ratio	Output Frequency	Package
XC225BS7008xR	44kHz +/-5%	256	11.264MHz	SOT25 USP-6C
XC25BS7012xR	92kHz +/-5%	256	23.552MHz	SOT25 USP-6C
XC25BS7013xR	184kHz +/-5%	128	23.552MHz	SOT25 USP-6C

Please note that all versions of the XC25BS7 are factory set. Please contact your local Torex sales representative for further information.

Schottky Barrier Diodes

The missing part of the puzzle!

Announcing a new range of **Schottky Barrier Diodes**

NEW DIODES in 5 PACKAGES

find out more - www.torex-europe.com



To enhance Torex's growing selection of DC/DCs, Charge Pumps & MOSFETs, a whole new series of Schottky Barrier Diodes has now been introduced. We are now able to supply our customers with DC/DC solutions that incorporate not only Torex's DC/DCs, but also our MOSFETs and Schottky Barrier Diodes!

Features

- Repetitive Peak Reverse Voltage: 30V, 40V, 60V
- Forward Current: 0.1A, 0.2A, 0.5A, 1A, 2A, 3A
- Packages: SOD-123A, SOD-323A, SOD-523, SOD-723, SMA

Part Number	IF	VR	VF	IR	Package
XBS013S15R	0.1A	30V	0.71V @ 100mA	2uA @ VR=25V	SOD-523
XBS013S16R	0.1A	30V	0.71V @ 100mA	2uA @ VR=25V	SOD-723
XBS024S15R	0.2A	40V	0.53V @ 200mA	2uA @ VR=40V	SOD-523
XBS053V13R	0.5A	30V	0.40V @ 500mA	100uA @ VR=20V	SOD-323A
XBS053V15R	0.5A	30V	0.40V @ 500mA	100uA @ VR=20V	SOD-523
XBS104S13R	1A	40V	0.49V @ 1A	200uA @ VR=40V	SOD-323A
XBS104S14R	1A	40V	0.49V @ 1A	200uA @ VR=40V	SOD-123A
XBS104V14R	1A	40V	0.65V @ 1A	2mA @ VR = 40V	SOD-123A
XBS203V17R	2A	30V	0.35V @ 2A	2mA @ VR=30V	SMA
XBS204S17R	2A	40V	0.485V @ 2A	200uA @ VR=40V	SMA
XBS206S17R	2A	60V	0.615V @ 2A	300uA @ VR=60V	SMA
XBS303V17R	3A	30V	0.355V @ 3A	3mA @ VR=30V	SMA
XBS304S17R	3A	40V	0.465V @ 3A	300uA @ VR=40V	SMA
XBS306S17R	3A	60V	0.59V @ 3A	300uA @ VR=60V	SMA

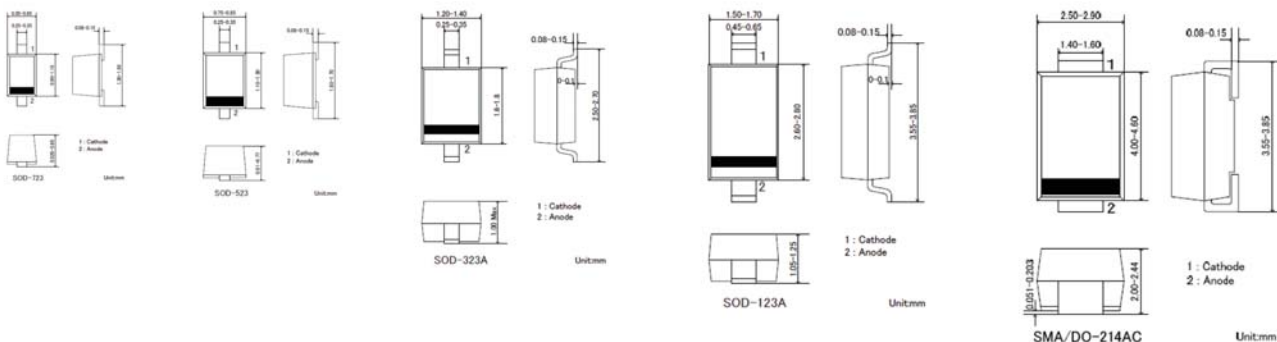

Selection Guide

Voltage Detectors / Voltage Regulators with Voltage Detectors

Voltage Detectors

Part Number	Type	Detect Voltage	Accuracy	Operating Voltage	Power Consumption	Output Configuration	On-chip delay circuit	Comments	Package
XC61C Series	Low Supply Current	0.8V ~ 6.0V	+/-2% (1%)	0.7V ~ 10V	Typ. 0.7 μ A	N-Channel Open Drain or CMOS	n/a	1% parts for output voltages between 2.6V~5.0V only	SC-82 SOT23 / 25 SOT89 TO92
XE61C Series	Low Supply Current	0.8V ~ 6.0V	+/-2% (1%)	0.7V ~ 10V	Typ. 0.7 μ A	N-Channel Open Drain or CMOS	n/a	Over Temperature Specs: -40°C to +85°C	SOT23 SOT89
XC61F Series	Built in Delay Circuit	1.6V ~ 6.0V	+/-2%	0.7V ~ 10V	Typ. 1.0 μ A	N-Channel Open Drain or CMOS	1ms to 50ms 50ms to 200ms (std) 80ms to 400ms		SOT23 SOT89 TO92
XC61G Series	Small Package	0.8V ~ 6.0V	+/-2%	0.7V ~ 10V	Typ. 0.7 μ A	N-Channel Open Drain or CMOS	n/a	1.2mm x 1.2mm x 0.6mm pkg	USP-3
XC6101 Series	Watchdog Timer & MR	1.6V~5.0V	+/-2%	1.0V~6.0V	Typ. 10 μ A	N-Channel Open Drain or CMOS	User Selectable	Hysteresis selectable from 2~8% & 0~1%	SOT25 USP-6C
XC6108 Series	External Delay & VSEN Pin	0.8V~5.0V	+/-2%	1.0V~6.0V	Typ. 0.8 μ A	N-Channel Open Drain or CMOS	Yes	External power supply monitoring	SOT25 USP-4
XC6109 Series	External Delay	0.8V~5.0V	+/-2%	0.7V~6.0V	Typ. 0.9 μ A	N-Channel Open Drain or CMOS	Yes	Cd pin for setting delay time	SC-82
NEW! XC6120 Series	Ultra Low Supply Current	1.0V ~ 5.0V	+/-1%	0.7V ~ 6.0V	Typ. 0.6 μ A	N-Channel Open Drain or CMOS	n/a	1% detect accuracy	USP-3 SC-82
NEW! XC6121 Series	Watchdog Timer	1.6V ~ 5.0V	+/-2%	1.0V ~ 6.0V	Typ. 10 μ A	N-Channel Open Drain	User Selectable from 100, 200 or 400ms	WD timeout period selectable from 100ms, 400ms, 1.6s	SOT25 USP-6C
XC612 Series	Dual Channel	1.5V ~ 5.0V	+/-2% (1%)	1.0V ~ 10V	Typ. 2.0 μ A	N-Channel Open Drain or CMOS	n/a	VD levels set independently	SOT25

Positive Voltage Regulators with built in Voltage Detector Function

Part Number	Type	Input Voltage Range	Output Voltage	Max Output Current	Accuracy	Power Consumption		Dropout Voltage	Detect Voltage Range	D.V.Output Configuration	Package
						Typical	Standby				
XC6402 Series	Low V-Drop	6V max	0.8V ~ 5.0V	> 700mA	+/-2%	35 μ A	n/a	50mV @ 100mA 60mV @ 30mA 200mV @ 100mA	0.8V ~ 5.0V	N-ch open drain	USP-6B SOT25 SOT89-5
XC6403 Series	Semi-custom		0.9V ~ 5.6V	> 300mA			0.1 μ A				
XC6404 Series	Delay circuit built-in		0.9V~5.1V	> 500mA			n/a				
XC6405 Series	Delay circuit built-in					90 μ A	n/a				
XC6413 Series	Semi-custom	10V max	0.9V~5.5V	> 300mA		35 μ A	0.1 μ A		0.9V~6.0V		USP-6B SOT25 SOT89-5
XC6414 Series				> 500mA							

Selection Guide

CMOS LDO Voltage Regulators

Positive Voltage Regulators

Part Number	Type	Input Voltage Range	Output Voltage	Max Output Current	Accuracy	Power Consumption		Dropout Voltage	Comments	Package
						Typical	Standby			
NEW! XB1085 Series	High Current	12V max	1.5V, 1.8V, 2.5V, 3.3V, 5.0V, & Adj.	3A	+/-1%	55µA*	n/a	1.3V @ 3A	Thermal Protection Built-In	T0-252
NEW! XB1086 Series	High Current	15V max	1.5V, 1.8V, 2.5V, 3.3V, 5.0V, & Adj.	1.5A	+/-1%	55µA*	n/a	1.3V @ 1.5A	Thermal Protection Built-In	T0-252
XB1117 Series	High Current	10V max	2.5V, 3.3V, 5.0V & Adj.	1A	+/-1%	55µA*	n/a	1.2V @ 1A	Bi-Polar	SOT223
XC62FP Series	General Purpose	10V max	1.1V ~ 6.0V	>250mA	+/-2% (1%)	2.0µA	n/a	120mV @ 100mA 380mV @ 200mA		SOT23 SOT89 T092
XC62RP Series	Reference Source	6V max	1.5V ~ 3.5V	6mA		3.2µA		140mV @ 300µA	Low output currents	SOT23 SOT89
XC6201 Series	Low ESR Caps	10V max	1.3V ~ 6.0V	>250mA		2.0µA		160mV @ 100mA	Low ESR Ceramics Capacitors	SOT25 SOT89 USP-6B T092
XC6202 Series	High Input Voltage	20V max	1.8V ~ 18V	>150mA	10.0µA	200mV @ 30mA		SOT23 SOT89 SOT223 USP-6B T092		
XC6203 Series	High Output Current	8V max	1.8V ~ 6.0V	>400mA	+/-2%	8.0µA		150mV @ 100mA 300mV @ 200mA		SOT23 SOT89 SOT223 T092
XC6206 Series	Low Quiescent Current	6V max	1.2V ~ 5.0V	>250mA		1.0µA		160mV @ 100mA 400mV @ 200mA	Low ESR Ceramics Capacitors	SOT23 SOT89 USP-6B T092
XC6214 Series	High Output Current	6V max	1.5V ~ 5.0V	>500mA		8.0µA		100mV @ 100mA 500mV @ 500mA	1.2V, 1.5V, 1.8V 2.5V, 3.0V, 3.3V Standard	SOT26 SOT89
NEW! XC6218 Series	Low Quiescent Current	6V max	0.9V ~ 4.0V	200mA		1.0µA		200mV @ 100mA	VOUT down to 0.9V	USP-3 SC-82

* 55µA is the typical figure with the adjustable output versions. For the figures for the fixed output voltage versions, please refer to the data sheet

Negative Voltage Regulators

Part Number	Type	Input Voltage Range	Output Voltage	Max Output Current	Accuracy	Power Consumption		Dropout Voltage	Comments	Package
						Typical	Standby			
XC62KN Series	General Purpose	-10V max	-2.1V to -6.0V	100mA	+/-2% (1%)	3.0µA	n/a	120mV @ 50mA 380mV @ 100mA		SOT23 SOT89 T092

Selection Guide

Positive Voltage Regulators with Output On/Off Control

Part Number	Type	Input Voltage Range	Output Voltage	Max Output Current	Accuracy	Power Consumption		Dropout Voltage	Comments	Package
						Typical	Standby			
XC6204 Series	Low Noise / High Speed	10V max	1.8V~6.0V	ABCD > 150mA EFGH > 300mA	+/-2% (1%*)	70µA	0.1µA	60mV @ 30mA 200mV @ 100mA	Low ESR Caps Noise 30µVrms typ PSRR > 70dB Fast turn-on time	SOT25 USP-6B SOT89-5
XC6205 Series	Low Noise / High Speed		0.9V~1.75V	>150mA						SOT25 USP-6B
XC6207 Series	Green Operation	6V max	0.8V~5.0V	>300mA	+/-2%	50µA (5.5µA)	0.1µA	40mV @ 30mA 135mV @ 100mA	Only 5.5µA quiescent current in power save mode	SOT25 USP-6C SOT89-5
XC6209 Series	Low Noise / High Speed	10V max	0.9V~6.0V	ABCD > 150mA EFGH > 300mA		25µA		60mV @ 30mA 200mV @ 100mA	Noise 30µVrms typ PSRR > 70dB	SOT25 USP-6B SOT89-5
XC6210 Series	High Current	6V max	0.8V~5.0V	>700mA	+/-2%	35µA	0.1µA	50mV @ 100mA 100mV @ 200mA	Ultra Low Dropout	SOT25 SOT89-5 USP-6B
XC6211 Series	Low Noise/ High Speed	6V max	0.9V~5.0V	~300mA		25µA		60mV @ 30mA 200mV @ 100mA	Noise 30µVrms typ PSRR > 70dB	SOT25
XC6212 Series	TK112 pin-out compatible	10V max	0.9V~6.0V	>150mA	+/-2%	35µA	0.1µA	60mV @ 30mA 200mV @ 100mA	Noise 30µVrms typ PSRR > 70dB	SOT25
XC6213 Series	Low Noise / High Speed	6V max	1.2V~5.0V	~150mA				400mV @ 100mA	V.small pkgs	SC-82 SOT25 USP-4
XC6215 Series	Ultra Low Iq		0.9V~5.0V	~200mA	+/-2%	0.8µA	0.1µA	320mV @ 100mA	Only 0.8µA Quiescent Current	SC-82 USP-4, USP-3 SOT25
XC6216 Series	High Voltage	28V max	2.0V~23V	~200mA		5µA		300mV @ 20mA	Fixed or Adjustable Outputs. XE6216 available with over temperature specs: -40°C to +80°C	TO-252 SOT223 SOT89 SOT89-5 SOT25 USP-6C
XC6217 Series	Green Operation	6V max	0.8V~4.0V	~200mA	+/-2%	25µA (4.5µA)	0.1µA	80mV @ 100mA	Only 4.5µA quiescent current in power save mode	SOT25 SC-82 USP-4D
XC6219 Series	Low Noise / High Speed		0.9V~5.0V	~300mA		25µA		60mV @ 30mA 200mV @ 100mA	Low Cost	USP-6B SOT25 SOT89-5
XC6221 Series	Low Noise / High Speed		0.8V~4.0V	~200mA		25µA		80mV @ 100mA	CL Auto Discharge	SOT25 SC-82 USP-4D

The XC6204 series is only available with a 1% output accuracy for voltages between 3.0V~6.0V

Selection Guide

Positive Voltage Regulators with Output On/Off Control continued...

Part Number	Type	Input Voltage Range	Output Voltage	Max Output Current	Accuracy	Power Consumption		Dropout Voltage	Comments	Package
						Typical	Standby			
NEW! XC6601 Series	Ultra Low Dropout	3V max	0.7V ~ 1.8V	400mA	+/-2%	25µA	0.1µA	35mV @ 100mA	Low voltage input operation	USP-6C
NEW! XC6701 Series	High Voltage / High Speed	28V max	1.8V ~ 18V	~ 200mA		20µA		300mV @ 20mA	28V input high speed CMOS LDO	TO-252 SOT223 SOT89 SOT89-5 SOT25 USP-6C
XC62E Series	Boosting	10V max	1.5V ~ 6.0V	> 1000mA		50µA	0.2µA	100mV @ 100mA < 400mV @ 1A	Ext. Transistor required	SOT25

Dual-Channel Positive Voltage Regulators

Part Number	Type	Input Voltage Range	Output Voltage	Max Output Current	Accuracy	Power Consumption		Dropout Voltage	Comments	Package
						Typical	Standby			
XC6401 Series	Dual Channel Low Noise / High Speed	6V max	0.8V ~ 5.0V	> 150mA/ch	+/-2%	25µA/ch	0.1µA	100mV @ 100mA	Low ESR Caps PSRR > 70dB Power Saving mode	USP-6B USP-6C SOT26W
XC6406 Series	Dual Current High Current	10V max	1.8V ~ 6.0V	> 400mA/ch		20.0µA/ch	n/a	150mV @ 100mA 300mV @ 200mA		SOP8 SOP8FD
XC6411 Series	Dual Channel Low Noise / High Speed	6V max	0.9V ~ 5.0V	~ 300mA/ch		0.8µA/ch	0.1µA	320mV @ 100mA	Dual LDO with dual input	SOT25
XC6412 Series	Dual Channel Low Noise / High Speed			~ 200mA/ch					Single input with EN pin on VR2	SOT26
NEW! XC6415 Series	Dual Channel Low Noise / High Speed		0.8V ~ 5.0V	~ 200mA/ch		28µA/ch		90mV @ 100mA	Low ESR Caps PSRR 65db CL Auto Discharge	USP-6C SOT26
NEW! XC6416 Series	Dual Channel Green Operation		0.8V ~ 5.0V	~ 200mA/ch		25µA/ch (4.5µA/ch)		80mV @ 100mA	Only 4.5µA/ch quiescent current in power save mode	USP-6C SOT26

Hide Side Switch

Part Number	Type	Input Voltage Range	Output Voltage	Max Output Current	Accuracy	Power Consumption		Dropout Voltage	Comments	Package
						Typical	Standby			
NEW! XC8101 Series	High Side Line Switch	6V max		~ 300mA	+/-2%	2µA			Low ON Resistance Line Switch IC	USP-4 SC-82 SOT25

Selection Guide

DC/DC Converters & Controllers

Step-up DC/DC Converters

Part Number	Type	Efficiency	Operating Voltage Range	Output Voltage Range	High Accuracy	Max. Oscillator Frequency	Comments	Package
XC6371 Series	PWM	Typ. 85%	0.9V ~ 10V	2.0V ~ 7.0V	+/-2.5%	50kHz, 100kHz & 180kHz (+/-15%)	Low Cost	SOT89 & SOT89-5
XC6372 Series	PFM / PWM							
XC6373 Series	PWM	Typ. 82%				30kHz	Low Noise	
XC9110 Series	PFM	87%	0.9V ~ 10V	1.5V ~ 7.0V	+/-2.5%	100kHz (+/-15%)	Fixed Duty Ratio	SOT25 USP-6C
XC9111 Series							Switchable Duty Ratio	
XC9116 Series	PWM	88%	2.5V ~ 6.0V	17.5V max	+/-5%	1MHz	Backlight LED Driver	SOT25 USP-6B
XC9119 Series	PWM	> 80%	2.5V ~ 6.0V	18.0V max	+/-2%	1MHz	High Switching Frequency	SOT25 USP-6C
NEW! XC9128 Series	Synchronous PWM PFM/PWM	93%	0.8V ~ 5.3V	1.8V ~ 5.3V	+/-2.2%	1.2MHz (+/-15%)	Thermal Shutdown, Over Current Limit, 5ms Soft-Start Time	SOT25 USP-6B
								SOP-8

Step-up DC/DC Controllers

Part Number	Type	Efficiency	Operating Voltage Range	Output Voltage Range	High Accuracy	Max. Oscillator Frequency	Comments	Package
XC6367 Series	PWM	Typ. 84%	0.9V ~ 10V	1.5V ~ 30V (fixed or adjustable)		100kHz, 180kHz, 300kHz, 500kHz	Output > 500mA Standby Current 0.5µA Max	SOT25
XC6368 Series	PFM/PWM							
XC9101 Series	PWM	Typ. 85%	20V max	1.5V ~ 30V (fixed or adjustable)		100kHz ~ 600kHz (user selectable)	Outputs upto 1.5A Low ESR ceramic caps	MSOP-8A
XC9103 Series	PWM	Typ. 85%	0.9V ~ 10V	1.5V ~ 30V (externally adjustable)	+/-2.5%	100kHz, 180kHz, 300kHz, 500kHz	Auto PFM / PWM	SOT25 USP-6B
XC9104 Series	PFM / PWM						Manual Switching Mode	
XC9105 Series	PFM / PWM							
XC9106 Series	PWM							
XC9107 Series	PFM / PWM						V-Ref input, adj. Vout LCD application	
XC9120 Series	PWM	Typ. 85%	0.9V ~ 6.0V	1.5V ~ 30V (externally adjustable)	+/-2%	100kHz	Max Duty 93%	SOT25 USP-6C
XC9121 Series	PFM / PWM						Auto PFM/PWM	
XC9122 Series	PFM / PWM						Manual Switching Mode	

Step-down DC/DC Converters

Part Number	Type	Efficiency	Operating Voltage Range	Output Voltage Range	High Accuracy	Max. Oscillator Frequency	Comments	Package
XC9215 Series	Synchronous PWM	Typ. 92%	2.0V ~ 6.0V	0.9V ~ 4.0V	+/-2%	600kHz or 1.2MHz	Outputs upto 500mA Low ESR ceramic caps	USP-6B SOT25
XC9216 Series	Synchronous PFM / PWM							
XC9217 Series	Synchronous PWM or PFM / PWM							
XC9223 Series	Synchronous PWM or PFM / PWM	Typ. 92%	2.2V ~ 6.0V	0.8V ~ VIN	+/-2%	1MHz, 2MHz	Outputs upto 1A Voltage Detector Option Low ESR ceramic caps	MSOP-10 USP-10 SOP-8
XC9224 Series								
XC9225 Series	Synchronous PWM	Typ. 92%	2.0V ~ 6.0V	0.9V ~ 4.0V	+/-2%	600kHz, 1.2MHz	Only 15µA Quiescent Current, Outputs up to 500mA	USP-6B SOT25
XC9226 Series	Synchronous PFM / PWM							
XC9227 Series	Synchronous PWM or PFM / PWM							
XC9228 Series	Synchronous PWM or PFM / PWM	Typ. 92%	2.0V ~ 6.0V	0.7V ~ 6.0V Vref	+/-2%	600kHz, 1.2MHz	Dynamic Output Voltage Outputs up to 500mA	USP-6B SOT25
XC9229 Series								
NEW! XC9235 Series	Synchronous PWM	Typ. 92%	2.0V ~ 6.0V	0.8V ~ 4.0V	+/-2%	1.2MHz, 3.0MHz	Outputs up to 600mA, Soft-Start Circuit Built-In	USP-6C SOT25
NEW! XC9237 Series	Synchronous PWM or PFM / PWM							
NEW! XC9515 Series	Synchronous Dual Channel	95%	~ 5.0V	Vout1: 1.2, 1.5, 1.8V Vout2: 3.3V	+/-2%	1MHz	Voltage Detector Built-In	QFN-20

The XC9225/26/27 series is also available with a 600mA output current option for output voltages between 3.0V ~ 4.0V (VIN range = 4.5V ~ 5.5V)

Selection Guide

Step-down DC/DC Converters with built-in Voltage Regulators and Detectors

Part Number	Type	Efficiency	Operating Voltage Range	Output Voltage /Detect Range	High Accuracy	Max. Oscillator Frequency	Comments	Package
XC9508 Series	Synchronous PWM or PFM / PWM	Typ. 94%	2.4V ~ 6.0V	DC/DC: 1.6V~4.0V VR: 0.9V~4.0V VD: 0.9V~5.0V	+/-2%	300kHz, 600kHz, 1.2MHz	DC/DC Iout > 600mA VR Iout > 300mA	MSOP-10 USP-10
XC9509 Series				DC/DC: 0.9V~4.0V VR: 0.9V~4.0V VD: 0.9V~5.0V				
XC9510 Series				DC/DC: 1.6V~4.0V VR: 0.9V~4.0V VD: 0.9V~5.0V			DC/DC Iout > 800mA VR Iout > 400mA	SOP-8
XC9511 Series				DC/DC: 0.9V~4.0V VR: 0.9V~4.0V VD: 0.9V~5.0V				

Step-down DC/DC Controllers

	Type	Efficiency	Operating Voltage Range	Output Voltage Range	High Accuracy	Max. Oscillator Frequency	Comments	Package
XC6365 Series	PWM	Typ. 92%	2.2V ~ 10V	1.5V ~ 6.0V (fixed or adjustable)	+/-2%	180kHz, 300kHz, 500kHz	Output Current > 1A Standby Current 0.5µA Max	SOT25
XC6366 Series	PFM / PWM							
XC9201 Series	PWM	Typ. 93%	2.5V ~ 20V	1.2V ~ 16V (fixed or adjustable)	+/-2.5%	100kHz ~ 600kHz (user selectable)	Outputs upto 3A Low ESR ceramic caps	MSOP-8A
XC9210 Series	Synchronous PFM/PWM	Typ. 90%	2.0V ~ 10V	0.9V ~ 6.0V	+/-2%	300kHz (+/-15%)	Outputs > 2A CE pin & internal soft-start	MSOP-8A
XC9213 Series	Synchronous PFM/PWM	Typ. 93%	4V ~ 25V	1.5V ~ 15V	+/-2%	300kHz (+/-15%)	Outputs > 5A Boot strap method	TSSOP-16
XC9220 Series	PWM	Typ. 93%	2.8V ~ 16V	1.2V~	+/-1.5%	300kHz, 500kHz, 1MHz	Outputs up to 3A Low ESR ceramic caps	SOT25 USP-6C
XC9221 Series	PFM/PWM							

Step-up & down DC/DC Controllers

Part Number	Type	Efficiency	Operating Voltage Range	Output Voltage Range	High Accuracy	Max. Oscillator Frequency	Comments	Package
XC9301 Series	PWM	Typ. 80%	2.0V ~ 10V	2.4V ~ 6.0V	+/-2.5%	180kHz, 300kHz (+/-15%)	Outputs > 250mA CE pin & internal soft-start	SOT25
XC9302 Series	PFM/PWM							
XC9303 Series	Synchronous PFM/PWM	Typ. 84%	2.0V ~ 10V	2.0V ~ 6.0V	+/-2%	300kHz (+/-15%)	Outputs > 800mA CE pin & internal softstart	MSOP-8A

Dual Channel DC/DC Controllers

Part Number	Type	Efficiency	Operating Voltage Range	Output Voltage Range	High Accuracy	Max. Oscillator Frequency	Comments	Package
XC9501 Series	Dual Step-up	Typ. 83%	2.0V ~ 10V	1.5V ~ 30V	+/-2%	180kHz (+/-15%) 300kHz, 500kHz (custom)	Switching Mode Pin: PWM or PFM/PWM Low ESR Ceramic Caps 3.0µA in Standby	MSOP-10
XC9502 series	Step-up+Step-down	Typ. 83% Typ. 92%		1.5V ~ 30V 0.9V ~ 6.0V				
XC9503 Series	Dual Step-down	Typ. 92%		0.9V ~ 6.0V				
XC9504 Series	Step-up+Inverting	Typ. 83% Typ. 76%		1.5V ~ 30V 30V ~ 0.0V				
XC9505 Series	Step-down+Inverting	Typ. 92% Typ. 76%		0.9V ~ 6.0V -30V~ 0.0V				

Selection Guide

Charge Pump Converters

Part Number	Type	Efficiency	Operating Voltage Range	Output Voltage Range	No Load Current	Max. Oscillator Frequency	Comments	Package
XC6351A120MR	Inverting	Typ. 90%	1.2V ~ 5.0V	-1.2V to -5.0V	310µA typ.	120kHz	Standby current 2.0µA	SOT26
XC9801/02 Series	Doubler / Regulated Step-up	Typ. 80%	1.8V ~ 5.5V	2.5V ~ 5.2V	80µA	300kHz	Standby current 2.0µA	USP-8 MSOP-8
NEW! XC9803 Series	White LED Driver		2.7V ~ 5.5V			1MHz	6 Channel Driver	QFN-20

Schottky Barrier Diodes

Part Number	IF	VR	VF1	VF2	IR	Package
NEW! XBS013S15R	0.1A	30V	0.31V @ 1mA	0.71V @ 100mA	2µA @ VR = 25V	SOD-523
NEW! XBS013S16R	0.1A	30V	0.31V @ 1mA	0.71V @ 100mA	2µA @ VR = 25V	SOD-723
NEW! XBS024S15R	0.2A	40V	0.33V @ 10mA	0.53 @ 200mA	2µA @ VR = 40V	SOD-523
NEW! XBS053V13R	0.5A	30V	0.28V @ 100mA	0.40V @ 500mA	100µA @ VR = 20V	SOD-323A
NEW! XBS053V15R	0.5A	30V	0.28V @ 100mA	0.40V @ 500mA	100µA @ VR = 20V	SOD-523
NEW! XBS104S13R	1A	40V	0.34V @ 100mA	0.49V @ 1A	200µA @ VR = 40V	SOD-323A
NEW! XBS104S14R	1A	40V	0.34V @ 100mA	0.49V @ 1A	200µA @ VR = 40V	SOD-123A
NEW! XBS104V13R	1A	40V	0.23V @ 100mA	0.30V @ 500mA	250µA @ VR = 40V	SOD-123A
NEW! XBS203V17R	2A	30V	0.28V @ 500mA	0.305V @ 1A	350µA @ VR = 30V	SMA
NEW! XBS204S17R	2A	40V	0.15V @ 200µA	0.485V @ 2A	6µA @ VR = 40V	SMA
NEW! XBS206S17R	2A	60V	0.15V @ 200µA	0.615V @ 2A	10µA @ VR = 60V	SMA
NEW! XBS303V17R	3A	30V	0.265V @ 500mA	0.295V @ 1A	350µA @ VR = 30V	SMA
NEW! XBS304S17R	3A	40V	0.135V @ 200µA	0.465V @ 3A	15µA @ VR = 40V	SMA
NEW! XBS306S17R	3A	60V	0.145V @ 200µA	0.59V @ 3A	9µA @ VR = 60V	SMA

Selection Guide

CMOS Mini-Logics

Part Number	Type	Operating Voltage Range	Input Voltage Range	Speed (tpd)	Power Consumption	Package
XC74UL Series	Single Logic Gate	2.0V ~ 5.5V	0.0V ~ 5.5V	4~8ns typ.	1.0μA Max	SSOT25
XC74WL Series	Dual / Triple Logic Gate	2.0V ~ 5.5V	0.0V ~ 5.5V	3~8.7ns typ.	1~2μA Max	MSOP-8

Operational Amplifiers

Part Number	Description	Gain Margin	Slew Rate	Power Consumption	Operating Voltage	Package
XC221A1100MR	Rail to Rail CMOS Op Amp	210kHz	0.07V/μS	15μA typ.	1.2V ~ 10V (single cell) +/-0.6V ~ 5V (+ve/-ve supply)	SOT25
XC221A1200MR	Rail to Rail CMOS Op Amp	550kHz	0.5V/μS	100μA typ.	1.2V ~ 10V (single cell) +/-0.6V ~ 5V (+ve/-ve supply)	SOT25

Analog Temperature Sensor

Part Number	Type	Temp. Range	Input Voltage Range	Output Voltage Range	Accuracy	Power Consumption		Output Voltage Temp. Coefficient	Package
						Typical	Standby		
XC31B Series	Bandgap Sensor	-30°C to +80°C	3.0V ~ 10V	2.0V ~ 6.0V	+/-3%	7μA	0.1μA	-3900ppm/°C typ.	SOT25

Oscillator IC's and PLL Clock Generator ICs

Part Number	Description	Oscillator Freq.	Op. Volt.	Divider Ratio	Multiplier Ratio	Output	Comments	Package
XC2163 Series	Divider / Buffer	20MHz ~ 125MHz (160MHz Buffer)	3.3V / 5.0V	f0/1, f0/2, f0/4, f0/8	n/a	3 state	3rd Overtone	SOT26
XC2164 Series	Divider / Buffer	4MHz ~ 125MHz	3.3V / 5.0V	f0/1, f0/2, f0/4, f0/8	n/a	3 state	Fundamental 3rd Overtone	SOT26 DIE
XC2165 Series	Divider / Buffer	8MHz ~ 120MHz	1.5V ~ 3.6V	f0/1, f0/2, f0/4, f0/8	n/a	3 state	Fundamental	SOT26 DIE
XC2173 Series	PLL	50MHz ~ 160MHz	3.3V / 5.0V	f0/2, f0/4, f0/8	f0 x 5,6,7,8	3 state		SOT26
XC2300 Series	Tri-State Buffer	70MHz (max)	3.3V / 5.0V	f0/1	n/a	3 state		SOT26
XC2301 Series	Tri-State Buffer	160MHz (max)	3.3V	f0/1, f0/2, f0/4, f0/8	n/a	3 state		SOT26
XC2311 Series	VCXO with built-in variable capacitor diode	16MHz~50MHz	2.6V~3.6V	n/a	n/a	n/a		SOT26 USP-6C SOP-8
XC25BS3 Series	PLL	9MHz~80MHz (Q0 = f0 x N/M)	2.97V~5.5V	1~2047	20~2047	3 state	CE Pin	SOT26 USP-6B
XC25BS5 Series	PLL	3MHz~30MHz (Q0 = f0 x N/M)	2.97V~5.5V	1~2047	6~2047	3 state	CE Pin	SOT26 USP-6B
XC25BS6 Series	Divider	32.768kHz	2.3V~4.0V	f0/1024, f0/512, f0/256, f0/128	n/a	3 state	CE Pin	SOT26
NEW! XC25BS7 Series	PLL	32kHz ~ 36MHz (Q0 = f0 x N/M)	2.5 ~ 5.5V	1 ~ 256	1 ~ 256	n/a	CE Pin	SOT25 USP-6C

With the XC25BS3 & XC25BS5, the second output (Q1) is selectable from reference oscillation, PLL output freq/2, comparative freq/2 or GND

Selection Guide

Power MOSFETs

N-Channel

Type Number	Absolute Max. Rating			Electrical Characteristic										Driving Voltage (V)	Package	
	Vdss (V)	Vgss (V)	Id (A)	Rds(ON) (Ω)								Vgs (off) (V)				Ciss (pF)
				Vgs=1.5V		Vgs=2.5V		Vgs=4.5V		Vgs=10V		MIN	MAX			
TYP	MAX	TYP	MAX	TYP	MAX	TYP	MAX	TYP	MAX	MIN	MAX					
XP131A1145SR	30	± 20	7	-	-	-	-	0.035	0.045	0.025	0.03	1.0	2.5	620	4.5	SOP-8 (Single)
XP131A1235SR	20	± 12	7	-	-	0.035	0.048	0.025	0.035	-	-	0.5	1.2	760	2.5	
XP131A1330SR	20	± 8	8	0.045	0.07	0.03	0.04	0.025	0.03	-	-	0.5	1.2	950	1.5	
XP131A1520SR	30	± 20	10	-	-	-	-	0.016	0.02	0.012	0.015	1.0	2.5	1370	4.5	
XP131A1617SR	20	± 12	10	-	-	0.013	0.019	0.01	0.014	-	-	0.7	1.4	1650	2.5	
XP131A1715SR	20	± 8	10	0.017	0.025	0.011	0.015	0.009	0.012	-	-	0.5	1.2	2000	1.5	SOP-8 (Dual)
XP133A1145SR	30	± 20	6	-	-	-	-	0.035	0.045	0.026	0.033	1.0	2.5	620	4.5	
XP133A1235SR	20	± 12	6	-	-	0.035	0.048	0.026	0.035	-	-	0.5	1.2	760	2.5	SOT-23 (Single)
XP133A1330SR	20	± 8	6	0.045	0.07	0.03	0.04	0.025	0.03	-	-	0.5	1.2	950	1.5	
XP151A11B0MR	30	± 20	1	-	-	-	-	0.13	0.17	0.09	0.12	1.0	3.0	150	4.5	SOT-23 (Single)
XP151A12A2MR	20	± 12	1	-	-	0.12	0.16	0.075	0.10	-	-	0.7	1.4	180	2.5	
XP151A13A0MR	20	± 8	1	0.17	0.25	0.10	0.14	0.075	0.10	-	-	0.5	1.2	220	1.5	
XP151A21A2MR	20	± 8	1	0.23	0.31	0.11	0.15	0.08	0.11	-	-	0.5	1.2	143	1.5	SOT-89 (Single)
XP161A11A1PR	30	± 20	4	-	-	-	-	0.075	0.105	0.05	0.065	1.0	2.5	270	4.5	
XP161A1265PR	20	± 12	4	-	-	0.07	0.095	0.042	0.055	-	-	0.7	1.4	320	2.5	
XP161A1355PR	20	± 8	4	0.10	0.15	0.05	0.07	0.037	0.05	-	-	0.5	1.2	390	1.5	

P-Channel

Type Number	Absolute Max. Rating			Electrical Characteristic										Driving Voltage (V)	Package	
	Vdss (V)	Vgss (V)	Id (A)	Rds(ON) (Ω)								Vgs (off) (V)				Ciss (pF)
				Vgs=-2.5V		Vgs=-4.5V		Vgs=-5.0V		Vgs=-10V		MIN	MAX			
TYP	MAX	TYP	MAX	TYP	MAX	TYP	MAX	TYP	MAX	MIN	MAX					
XP132A11A1SR	-30	± 20	-5	-	-	0.095	0.11	-	-	0.055	0.065	-1.0	-2.5	680	-4.5	SOP-8 (Single)
XP132A1275SR	-20	± 12	-5	0.092	0.115	0.05	0.075	-	-	-	-	-0.5	-1.2	770	-2.5	
XP132A1545SR	-30	± 20	-8	-	-	0.038	0.045	-	-	0.025	0.03	-1.0	-2.5	1500	-4.5	
XP132A1635SR	-20	± 12	-8	0.04	0.055	0.025	0.033	-	-	-	-	-0.5	-1.2	1700	-2.5	SOP-8 (Dual)
XP134A11A1SR	-30	± 20	-4	-	-	0.09	0.11	-	-	0.055	0.065	-1.0	-2.5	680	-4.5	
XP134A1275SR	-20	± 12	-4.5	0.095	0.115	0.062	0.075	-	-	-	-	-0.5	-1.2	770	-2.5	SOT-23 (Single)
XP152A11E5MR	-30	± 20	-0.7	-	-	0.35	0.45	-	-	0.2	0.25	-1.0	-3.0	160	-4.5	
XP152A12C0MR	-20	± 12	-0.7	0.37	0.5	0.23	0.3	-	-	-	-	-0.5	-1.2	180	-2.5	
XP152A21B2MR	-20	± 12	-0.7	0.37	0.5	0.23	0.3	-	-	-	-	-0.5	-1.2	135	-2.5	SOT-89 (Single)
XP162A11C0PR	-30	± 20	-2.5	-	-	0.2	0.28	-	-	0.11	0.15	-1.0	-2.5	280	-4.5	
XP162A12A6PR	-20	± 12	-2.5	0.22	0.3	0.13	0.17	-	-	-	-	-0.5	-1.2	310	-2.5	

*1) : @ Vgs=-5.5V

N-Channel & P-Channel (Complementary)

Type Number	Absolute Max. Rating			Electrical Characteristic										Driving Voltage (V)	Package	
	Vdss (V)	Vgss (V)	Id (A)	Rds(ON) (Ω)								Vgs (off) (V)				Ciss (pF)
				Vgs=±1.5V		Vgs=±2.5V		Vgs=±4.5V		Vgs=±10V		MIN	MAX			
TYP	MAX	TYP	MAX	TYP	MAX	TYP	MAX	TYP	MAX	MIN	MAX					
XP135A1145SR	30	± 20	5	-	-	-	-	-	0.045	-	0.03	1	2.5	520	4.5	SOP-8
	-30	± 20	-3.5	-	-	-	-	-	0.11	-	0.065	-1	-2.5	600	-4.5	

LATEST RELEASES

New Ultra Low Power Supervisor ICs XC6120 Series

With a typical supply current figure of only **0.6 μ A** (VDF=2.0V, VIN=2.2V), the new XC6120 voltage detector offers one of the lowest power consumption performances on the market today.

- Detect Voltage Range: 1.0V~5.0V
- Operating Voltage Range: 0.7V~6.0V
- Detect Accuracy:
 - +/-1% (VDF(T) > 2.0V)
 - +/-20mV (VDF(T) < 2.0V)
- Packages: USP-3, SC-82

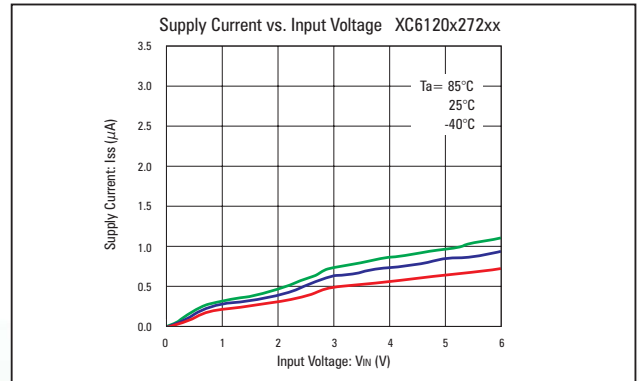

XC6121/22/23/24 Series

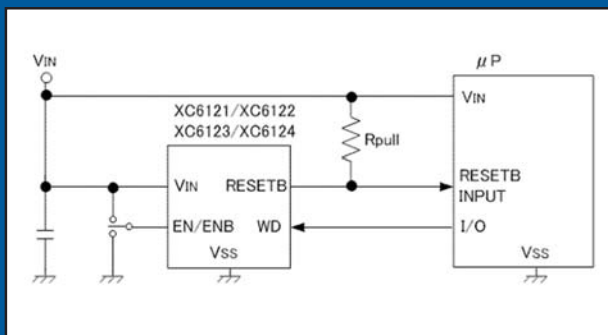

Typical Application Circuit

In addition to low supply current performance, the new XC6121/22/23/24 series of supervisor ICs also incorporate a watchdog function. Watchdog timeout periods are selectable from 100ms, 400ms or 1.6s. Release delay time is selectable from 100ms, 200ms or 400ms. Output configuration is N-channel open drain for all four versions.

- Detect Voltage Range : 1.6V~5.0V
- Operating Voltage Range : 1.0V~6.0V
- Hysteresis Range : VDFL x 5% (typ)
- Packages : USP-6C, SOT-25

Torex Semiconductor Europe Ltd.

Unit 1, The Courtyard Whitwick Business Park,
Stenson Road, Coalville, Leicestershire,
LE67 4JP, UK
Tel: +44-1530-510190
Fax: +44-1530-512400
Email: sales@torexsemi.co.uk

TOIREX

www.torex-europe.com