

PIN CONFIGURATION

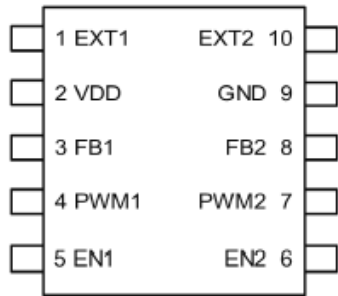

MSOP-10
(TOP VIEW)

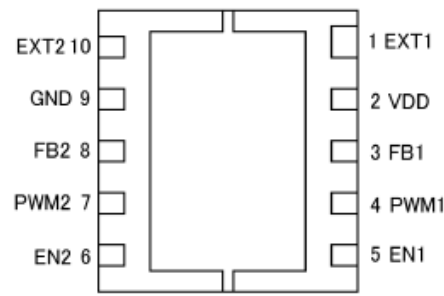

USP-10
(BOTTOM VIEW)

● MSOP-10

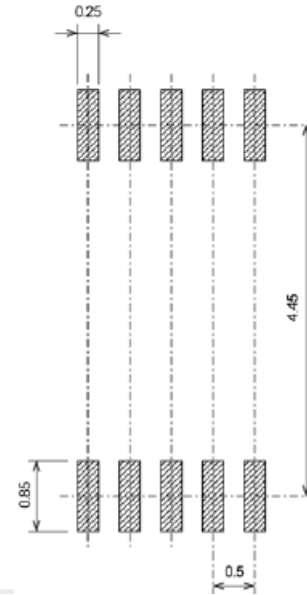

● USP-10

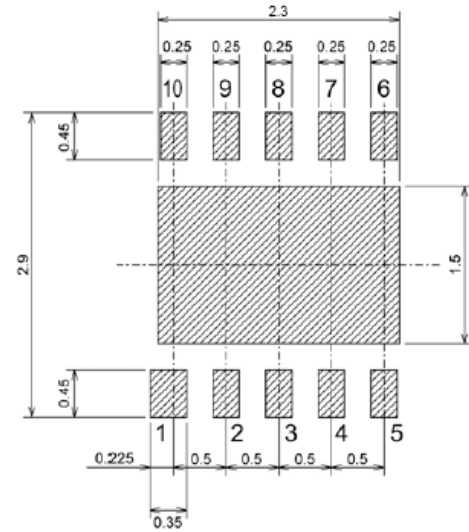

Note: Recommended metal design

PACKAGING INFORMATION

● MSOP-10

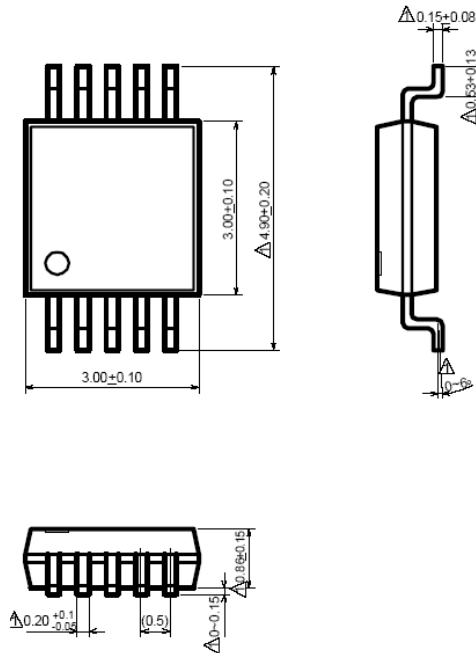

● USP-10

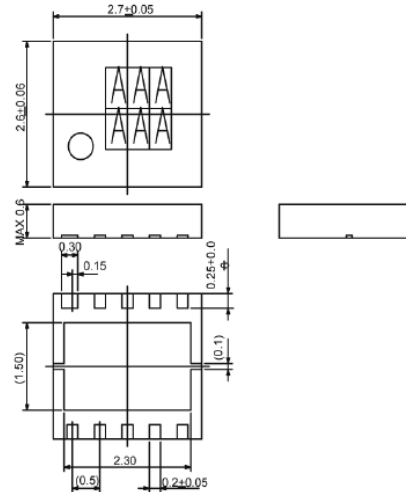

* Soldering fillet surface is not formed because the sides of the pins are not plated.

